

Standard Panel Insert Flanged Bracket Mounting

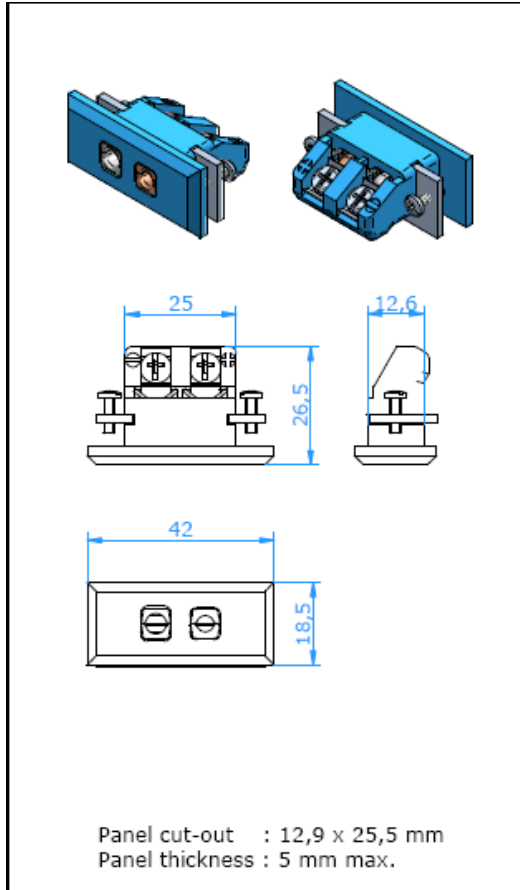

APPLICATION:

Panel insert for thermocouple and RTD circuits. Mounting by means of a stainless steel bracket and two screws.

CONSTRUCTION:

- Glass filled thermoplastic body with original thermocouple material pins and springloaded inserts.
- Polarized pins ensure proper connection.
- Molded barriers prevent short circuit.
- Polarity indication on the body
- Rugged one body design.
- Stainless steel screws and bracket for rear mounting (also available with metal spring-clip)

WIRE SIZE:

- Accepts wires from 0,2 mm to 2,0 mm.

TEMPERATURE RATING:

- 200 °C Max.

COLOR CODE:

- Available in all color code standards incl. NFE, BS, JIS, etc.

ORDERING CODE

PSIF-xx
PSIFB-xx

For last two digits 'xx' see table below

Calibration Code	E	J	K	N	T	U	R/S	C	B
Compensation material for							Pt13Rh Pt	W5Re W26Re	Pt6Rh/ Pt30Rh
Material Positive	NiCr	Fe	NiCr	NiCrSi	Cu	Cu	Cu	CPX	Cu
Material Negative	CuNi	CuNi	NiAl	NiSi	CuNi	Cu	Alloy 11	CNX	Cu
IEC Color Code									
Color Body	Violet	Black	Green	Pink	Brown	White	Orange	Red	Grey
Code	EI	JO	KI	NI	TI	UI	RI	C	BI
ANSI Color Code									
Color Body	Violet	Black	Yellow	Orange	Blue	White	Green	Red	Grey
Code	EI	JI	KA	NA	TA	UI	RA	C	BI
DIN Color Code									
Color Body		Blue	Green		Brown		White		Grey
Code		JD	KI		TI		RD		BI