



MINIATURE RUGGEDIZED PRESSURE TRANSDUCER

HKL-375 (M) CO SERIES

- Excellent Stability
- All Welded Construction
- Robust Construction
- High Natural Frequencies
- 3/8-24 UNJF or M10 X 1 Thread
- Patented Leadless Technology **VIS**[®]

The HKL-375 is a miniature threaded pressure transducer. The hexagonal head and o-ring seal make it easy to mount and simple to apply.

The HKL-375 utilizes Kulite's Patented Leadless Technology. A solid state piezoresistive sensing element is protected by a metal screen. This sensing sub assembly is welded to a stainless steel body.

This advanced construction results in a highly stable, reliable and rugged instrument with all the advantages of significant miniaturization, excellent repeatability, low power consumption, etc. The miniaturization process also yields a marked increase in the natural frequencies of the transducers, making them suitable for use even in shock pressure measurements.

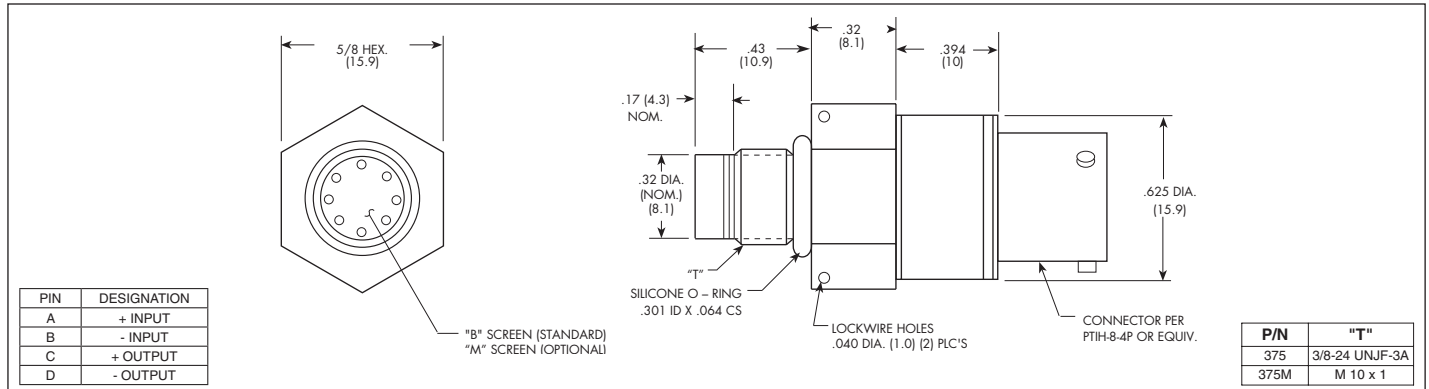

	0.7	1.0	1.7	3.5	7 BAR	
	10	15	25	50	100 PSI	
INPUT	Pressure Range	0.7	1.0	1.7	3.5	7 BAR
	Operational Mode	Absolute		Absolute, Sealed Gage		
	Over Pressure	2 Times Rated Pressure				
	Burst Pressure	3 Times Rated Pressure				
	Pressure Media	Most Conductive Liquids and Gases - Please Consult Factory (All Media May Not Be Suitable With O-Ring Supplied)				
	Rated Electrical Excitation	10 VDC/AC				
	Maximum Electrical Excitation	12 VDC/AC				
	Input Impedance	1000 Ohms (Min.)				
OUTPUT	Output Impedance	1000 Ohms (Nom.)				
	Full Scale Output (FSO)	100 mV (Nom.)				
	Residual Unbalance	± 5 mV (Typ.)				
	Combined Non-Linearity, Hysteresis and Repeatability	± 0.1% FSO BFSL (Typ.), ± 0.5% FSO (Max.)				
	Resolution	Infinitesimal				
	Natural Frequency of Sensor Without Screen (KHz) (Typ.)	Greater Than 175 KHz				
	Acceleration Sensitivity % FS/g Perpendicular	1.0x10 ⁻³	6.5x10 ⁻⁴	5.0x10 ⁻⁴	3.0x10 ⁻⁴	1.5x10 ⁻⁴
	Insulation Resistance	100 Megohm Min. @ 50 VDC				
ENVIRONMENTAL	Operating Temperature Range	-65°F to +250°F (-55°C to +120°C)				
	Compensated Temperature Range	+80°F to +180°F (+25°C to +80°C) Any 100°F Range Within The Operating Range on Request				
	Thermal Zero Shift	± 1% FS/100°F (Typ.)				
	Thermal Sensitivity Shift	± 1% /100°F (Typ.)				
	Linear Vibration	10-2,000 Hz Sine, 100g. (Max.)				
PHYSICAL	Humidity	100% Relative Humidity				
	Mechanical Shock	20g half Sine Wave 11 msec. Duration				
	Electrical Connection	PTIH-8-4P Connector or Equivalent				
	Weight	17 Grams (Max.)				
	Pressure Sensing Principle	Fully Active Four Arm Wheatstone Bridge Dielectrically Isolated Silicon on Silicon Patented Leadless Technology				
Mounting Torque	80 Inch-Pounds (Max.) 9 Nm					

Note: Custom pressure ranges, accuracies and mechanical configurations available. Dimensions are in inches. Dimensions in parenthesis are in millimeters.

Continuous development and refinement of our products may result in specification changes without notice - all dimensions nominal.

Kulite miniature pressure transducers are intended for use in test and research and development programs and are not necessarily designed to be used in production applications. For products designed to be used in production programs, please consult the factory.