

DT262

Relative Humidity & Temperature Transmitter



The DT262 has been developed for high precision measurement of relative humidity and temperature. This transmitter is available with a range of outputs.

Highlights

- Designed for accurate measurement in controlled environment
- Output signal configurable on request
- Linearization for a specific isotherm on request

Technical Specifications

Performance	
Measurement range (RH)	0–100% RH
Measurement range (T)	-20 to +80°C / -4 to +176°F
Accuracy at 23°C / 73°F Humidity	<±2% RH (5–95% RH)
Accuracy at 23°C / 73°F Temperature	±0.2°C (-10 to +50°C) ±0.36°F (14 to +122°F)
Stability – RH Sensor	±1% RH/year
Response time – RH Sensor	<10 sec typical (for 90% of the step change)
Electrical output/input	
Output signal (RH) configurable on request	4–20 mA 0–1 V, 0–5 V, 0–10 V
Output signal (T) configurable on request	4–20 mA 3-wire 1/3 DIN Pt100 direct 0–1 V, 0–5 V, 0–10 V
Supply voltage	Output 4–20 mA: V+ = 12–30 VDC Output 0–10 V: V+ = 15–30 VDC Output 0–5 V: V+ = 10–30 VDC Output 0–1 V: V+ = 8–30 VDC
Load resistance	Output 4–20 mA: Rload < (Uv-9)/0.02 Output 0–10 V: R > 10 k Ω Output 0–5 V: R > 5 k Ω Output 0–1 V: R > 1 k Ω
Current consumption	2 x 20 mA max
Operating conditions	
Operating humidity	Probe: 0–100% RH Housing, Storage: 0–98% RH (non-condensing)
Operating temperature	Probe: -30 to +85°C / -22 to +185°F Housing: -30 to +70°C / -22 to +158°F Storage: -40 to +70°C / -40 to +158°F
Mechanical specification	
Ingress protection	IP65
Material	PPO + POM
Dimensions	Housing: 80 x 80 x 34.5mm / 3.14 x 3.14 x 1.35" Probe: L=85/178mm, ø12mm / L=3.34/7.00", ø 0.47"
Weight	100g / 3.53oz
Electrical connections	Screw terminals

Accessories and spare parts

You can check your hygrometer with the control kit HKC which is based on the principle of non-saturated salt solutions. Refer to technical data sheet CONTROL KIT

Control Kit HKC

Aluminum mounting flange for fixing probe

FLA012

Dimensions

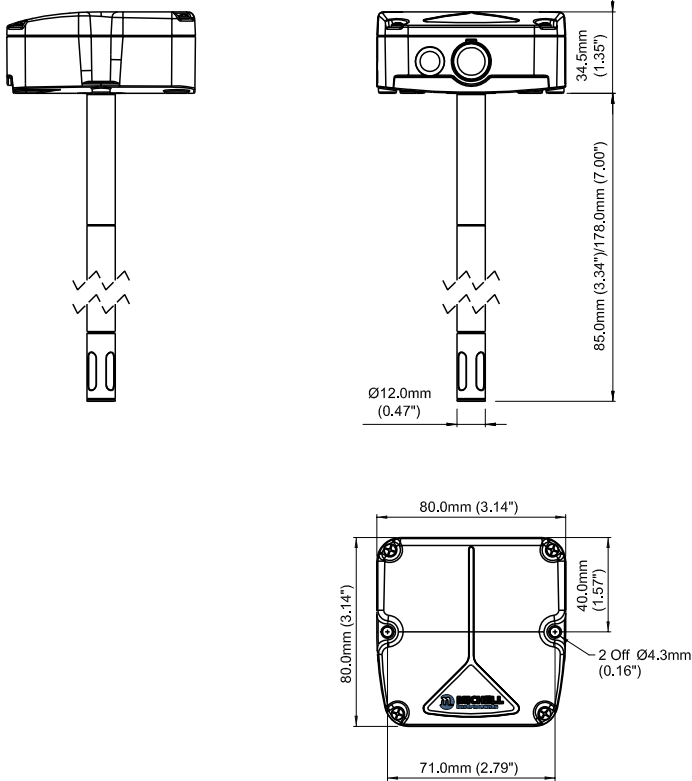

Electrical Connections

Version mA output and Pt100 direct	
Pin 1	Output RH +
Pin 2	Output RH -
Pin 3	
Pin 4	
Pin 5	Pt100 direct

Version mA output for RH and Temperature	
Pin 1	Output temperature +
Pin 2	Output temperature -
Pin 3	Output RH +
Pin 4	Output RH -

Warning:
Temperature channels Pin 1 and Pin 2 must be powered always.

Version V output and Pt100 direct	Version V output for RH and Temperature
Pin 1	Power supply V+
Pin 2	Common ground
Pin 3	Output RH +
Pin 4	
Pin 5	
Pin 1	Power supply V+
Pin 2	Common ground
Pin 3	Output Temperature +
Pin 4	Output RH +

Order codes

Relative humidity transmitter **DT262 A 3 0 Z10**

Humidity signal output	
4–20 mA	A
0–10 V	B
0–5 V	C
0–1 V	D

Temperature output configuration	
No temperature output	0
Pt100 direct (standard)	1
-30 to +70°C / -22 to +158°F Range	3
-30 to +20°C / -22 to +68°F Range	4
0 to +50°C / 32 to +122°F Range	5
-20 to +80°C / -4 to +176°F Range	6
Other output scaling available on request	TX

Protections and filters	
Polyester mesh + PTFE filter	Z10

Extension	
Length 85.0mm / 3.35"	0
Length 178.0mm / 7.01"	1

Example: DT262 A 3 0 Z10

Relative humidity transmitter DT262 with 4–20 mA humidity signal output, -30 to +70°C / -22 to +158°F temperature range, 85mm / 3.35" extension, with polyester mesh and PTFE filter.

Please note: Michell Instruments adopts a continuous development program which sometimes necessitates specification changes without notice. Please contact us for latest version. Ref: DT262_97187_V1_UK_1009