

H5000 & 5100

Capacitive Relative Humidity Sensor

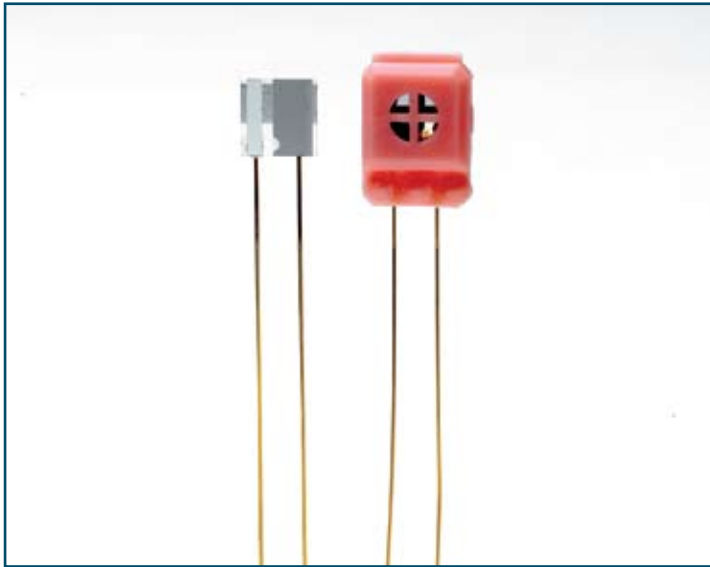

The operating principle of these capacitive relative humidity sensors are based on the hygroscopic properties of their polymer, which is used like a dielectric in a capacitor. The polymer gets in equilibrium with its humid environment quickly, and reversibly, and changes its capacity value depending on the humidity level.

Highlights

- Capacitive thin film sensor
- Measuring range: RH 0–100%, Temp: -30 to +200°C / -22 to +365°F
- Mixing ratio: 250g / 8.82oz water/Kg of dry air
- Low hysteresis
- Response time: 4 seconds

Dimensions

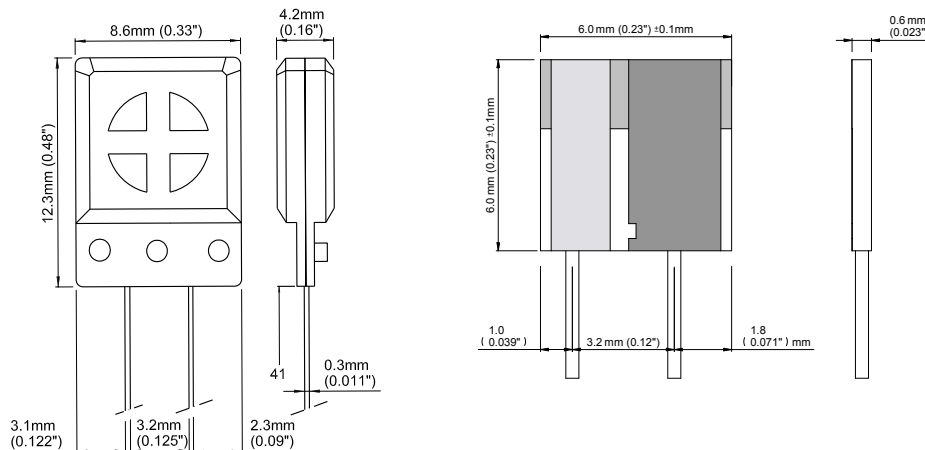

Technical Specifications

	H5000	H5100
Response time 90% of scale for a step change from 11% to 75% RH	4 sec	4 sec
Operating range		
Humidity	0–100% RH	0–100% RH
Temperature	-30 to +200°C	-30 to +100°C
Pressure	/ -22 to +392°F	/ -22 to +212°F
	0.04–30 bar / 0.6-400 psi	0.04–30 bar / 0.6-400 psi
Mixing ratio	250g water/Kg dry air	
Nominal capacity 75% RH @ 23°C / 73°F	500 pF ± 10%	
Sensitivity 11-75% RH @ 23°C / 73°F	0.86 pF/% RH	
Linearity 11–90% RH @ 23°C / 73°F	± 2.5% RH	
Long term stability (12 months) control @ 11% RH	< 1% at 23°C / 73°F	
Maximum air speed (without protection)	< 20m/sec	
Hysteresis	Typical value = 0.5% RH	
D Factor loss tangent @10 KHz 75% RH @ 23°C / 73°F	Typical value = 0.007	
Supply voltage Peak-to-peak	2.5 VAC DC component < 0.2 V	
Operating frequency range	5–300 KHz	
Protection cap	No	Yes
Weight	0.1g / 0.0004oz	1g / 0.035oz

Order Codes

H5000	Minimum order 50 pieces
H5100 (with protective cap)	Minimum order 50 pieces

Please note: Michell Instruments adopts a continuous development program which sometimes necessitates specification changes without notice. Please contact us for latest version. Ref: H5000_97197_V1_UK_1009