

RM33 & 52

Relative Humidity and Temperature Transmitter, HVAC Room Mount



The RM series of relative humidity and temperature transmitters offers a comprehensive range of output signals and measurement ranges. The transmitters are housed in a wall mounting enclosure making these instruments ideal for HVAC and building management applications.

Highlights

- Designed for low cost HVAC applications
- Quick installation: electrical rear connection with screw terminals
- Long term stability

Technical Specifications

Performance	
Measurement range (RH)	0–100% RH
Measurement range (T)	0 to +50°C / 32 to 122°F
Accuracy at 23°C / 73°F Humidity	RM52: $\pm 2\%$ RH (10–90% RH) RM33: $\pm 3\%$ RH (30–80% RH)
Accuracy at 23°C / 73°F Temperature	RM52: $\pm 0.2^{\circ}\text{C}$ (-10 to +50°C) $\pm 0.36^{\circ}\text{F}$ (14 to 122°F) RM33: $\pm 0.3^{\circ}\text{C}$ (5 to 40°C) $\pm 0.54^{\circ}\text{F}$ (41 to 104°F)
Temperature influence	$\pm 0.05\% \text{ RH}/^{\circ}\text{C}$ / $\pm 0.027\% \text{ RH}/^{\circ}\text{F}$
Stability – RH Sensor	$\pm 1\% \text{ RH}/\text{year}$
Response time – RH Sensor	<10 sec typical (for 90% of the step change)
Electrical output/input	
Output signal	0–1 VDC, 0–5 VDC, 0–10 VDC 4–20 mA (2-wire)
Supply voltage	14–35 VDC (for 0–5 / 10 VDC 4.5–35 VDC (for 0–1 VDC) and 14–26 VAC
Supply voltage influence	$\pm 0.01\% \text{ RH}/\text{V}$ typical
Operating conditions	
Operating humidity	10–90% RH Probe, Housing, Storage
Operating temperature	Electronics: 0 to +50°C / 32 to 122°F Storage: -40 to +75°C / -40 to +167°F
PRT	
Measurement range	Pt100/1000: -50 to +200°C / -58 to +392°F
Accuracy	Pt100/1000: $\pm 0.15\%$
Mechanical specification	
Ingress protection	N/A
Housing material	White moulded polymer housing
Dimensions	91 x 91 x 25.5 mm / 3.58 x 3.58 x 1.00"
Filter	N/A
Weight	85g / 3oz
Electrical connections	Screw terminals

Dimensions

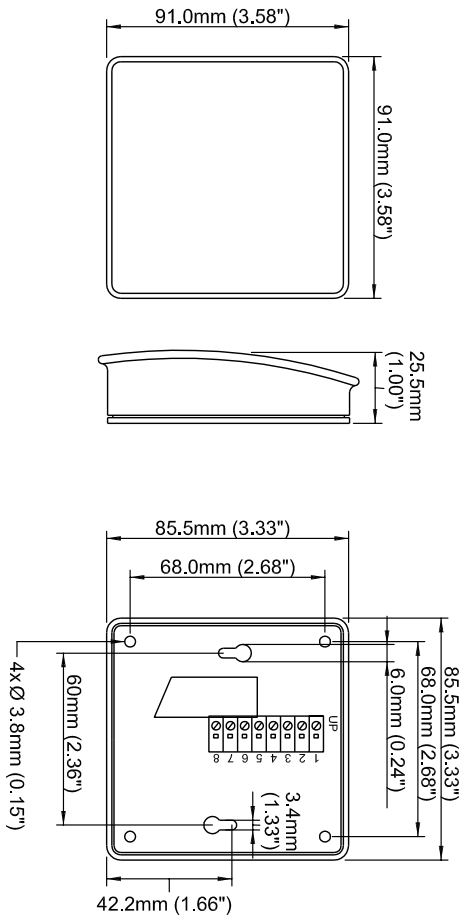

Electrical Connections

Voltage output	
Pin 1	Pin 1
Pin 2	Pin 2
Pin 3	Pin 3
Pin 4	Output temperature +
Pin 5	Output RH +
Pin 6	Common ground
Pin 7	Power supply V+
Pin 8	Pin 8

Temperature sensor
Pt100/Pt1000

Humidity with temperature sensor

mA output	
Pin 1	Output RH +
Pin 2	Output RH -
Pin 3	Pin 3
Pin 4	Pin 4
Pin 5	Pin 5
Pin 6	Pin 6
Pin 7	Pin 7
Pin 8	Pin 8

Temperature sensor

Humidity with temperature sensor

Order codes

Relative humidity and temperature transmitter

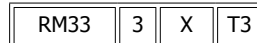

Accuracy configuration	
3% accuracy	RM33
2% accuracy	RM52

Output configuration	
4–20 mA analog output	2
0–10 V analog output	3
0–5 V analog output	4
0–1 V analog output	5

Temperature output configuration	
No temperature output, RH signal only	X
0 to +50°C / 32 to 122°F (standard)	T3
Pt100: -50 to +200°C / -58 to +392°F class A	T4
Pt1000: -50 to +200°C / -58 to +392°F class A	T5
Other output scaling available on request	TX

Example: RM33 3 X T3

Relative humidity and temperature transmitter RM33, HVAC 3% accuracy, 0–10 V analog output, RH signal, 0 to +50°C / 32 to 122°F (standard) temperature range.

Please note: Michell Instruments adopts a continuous development program which sometimes necessitates specification changes without notice. Please contact us for latest version. Ref: RM 33&52_97182_V1_UK_1009