

USB - Torque Sensor with Configuration and Evaluation Software

DR-3000

- Measuring ranges 0.5 ... 1000 N.m
- Up to 2500 Measurements/s
- 16-Bit digitalization in sensor directly
- Feed-in from USB, without ext. power supply
- Suited for mobile operation with a notebook
- Calibration parameter lodged in sensor
- Calibration control actuation by software
- Power computation by software



This sensor has non-contact digital signal transmission from rotor to stator, thus no signal falsification and without maintenance.

Order number	Measuring range [N·m]	Weight [kg]	Max. speed [min ⁻¹]	Springrate [N·m/rad]	Mass moment of inertia [kg·m ²]		Natural frequency [Hz]
					Drive side	Test side	
111231	0.5	0.5	30000	4.5E+01	1.1E-05	1.8E-07	2.5E+03
111177	1	0.5	30000	4.6E+01	1.1E-05	1.8E-07	2.6E+03
111232	2	0.5	30000	3.2E+02	1.1E-05	1.8E-07	6.7E+03
111233	5	0.5	30000	5.6E+02	1.1E-05	1.9E-07	8.6E+03
111234	10	0.6	30000	5.9E+02	1.1E-05	2.0E-07	8.7E+03
111235	20	1.5	20000	4.4E+03	1.2E-04	6.8E-06	4.2E+03
111236	30	1.5	20000	4.4E+03	1.2E-04	6.8E-06	4.2E+03
111114	50	1.5	20000	8.2E+03	1.2E-04	7.3E-06	5.5E+03
111237	100	1.5	20000	8.2E+03	1.2E-04	7.3E-06	5.5E+03
111238	200	4.8	15000	7.3E+04	5.6E-04	4.5E-04	2.7E+03
111239	300	4.8	15000	7.3E+04	5.6E-04	4.5E-04	2.7E+03
110554	500	4.8	15000	7.3E+04	5.6E-04	4.5E-04	2.7E+03
111240	1000	5.1	15000	1.6E+05	6.6E-04	5.4E-04	3.7E+03

SPECIFICATIONS

Type		DR-3000
Accuracy class torque	% f. s.	0.1
Speed resolution	min ⁻¹	1
Speed accuracy	% f. s.	<1
Angle of rotation resolution	Degree	0.25
Repeatability acc. DIN 1319	%	±0.02
Feed-in from USB	V DC	4 ... 6
Current consumption	mA	<250
Output signal torque	digits	0 ... ±25000 ¹⁾
Output signal speed / angle of rotation	digits	0 ... ±32511 ¹⁾
Input calibration control actuation		per Software
Sample rate	KSample	2.5
Reference temperature	°C	+23
Nominal temperature range	°C	+5 ... +45
Service temperature range	°C	0 ... +60
Storage temperature range	°C	-10 ... +70
Temperature coefficient of characteristic value	% f. s./K	+0.01
Temperature coefficient of zero signal	% f. s./K	±0.02
Service torque (static)	% f. s.	150
Limit torque (static)	% f. s.	200
Ultimate torque (static)	% f. s.	>300
Cutoff frequency (-3dB)	kHz	1
Oscillation amplitude (DIN 50 100)	%	70 (peak - peak)
Level of protection (DIN EN 60529)		IP50
Electrical connection		PX0446 IP68 B Mini USB, incl. 3 m connection cable to PC

¹⁾ ± indicates the rotational direction for clockwise and/or anticlockwise rotation

Dimensions

DR-3000

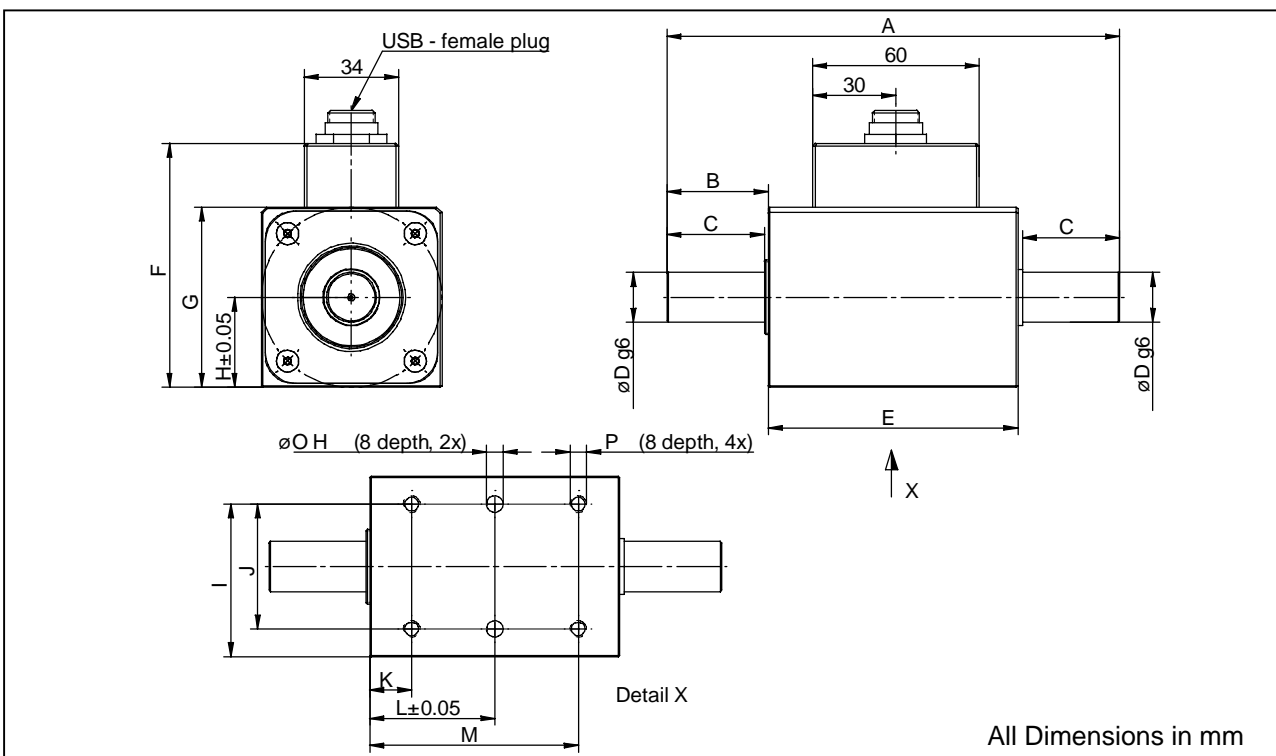

Measuring range [N·m]	Dimensions [mm]														
	A	B	C	ØD	E	F	G	H	I	J	K	L	M	O	P
0.5 / 1 / 2 / 5	110	19	17	8	71	63	40	20	35	30	12	35.5	59	4	M4
10	110	19	17	10	71	63	40	20	35	30	12	35.5	59	4	M4
20 / 30 / 50 / 100	163	36.5	35	18	90	88	65	32.5	55	45	15	45	75	6	M6
200 / 300 / 500	234	56.5	55	32	120	118	95	47.5	82.5	70	20	60	100	8	M8
1000	234	56.5	55	42	120	118	95	47.5	82.5	70	20	60	100	8	M8

Configuration and Evaluation Software

DR-3000-VS

- Convenient configuration and evaluation software
- Graphic presentation of torque/ speed/ power or torque/ angle of rotation
- Automatic scaling of y-axis
- Simultaneous storage of up to 3 physical values
- Automatic storage function of the measured values as CSV- or BMP- File

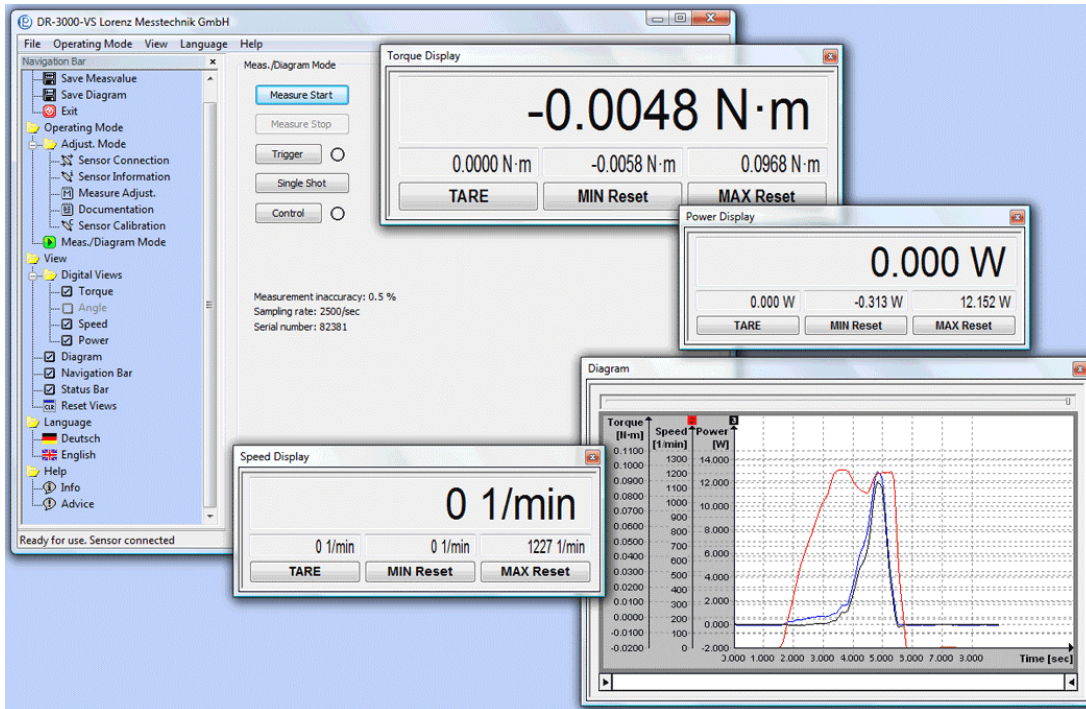

DESCRIPTION

Configuration and evaluation software for easy analysis and graphic presentation on a PC.

The software for the DR-3000 allows direct read in of measured data into a text file in CSV-Format through the USB-Port of a PC. This enables further analyses with a commercially available spreadsheet program at any time.

SPECIFICATIONS

Type	DR-3000-VS
Interface	USB (for operation with DR-3000))
Protocol	Lorenz standard protocol
System requirements	ex Win2000® Single- Core ex 2.0 GHz (without diagram) Dual- Core ex 1.8 GHz (with diagram)

Conversion in physical values	✓
Simultaneous measuring	1 Sensor
Graphic presentation of a physical value	✓
Automatic or manual storage in a CSV and BMP file	✓
Mathematical computation of the mechanical power	✓
Calibration function	✓
Resettable minimum value memory for each measured value	✓
Resettable maximum value memory for each measured value	✓
Variable average determination	✓
Tare for each measured value	✓

Windows® is either a registered brand or brand of the Microsoft Corporation in the USA and/or other countries.

All trademarks or brands used in this document refer only to the respective product or the holder of the trademark or brand. Lorenz Messtechnik GmbH does not raise claims to other than their own trademarks or brands.