



MINIATURE IS® PRESSURE TRANSDUCER

ETL-79-HA-DC-190 SERIES

- Robust Construction
- Ultra Miniature Amplified Version
- Microprocessor Corrected
- High Accuracy
- Patented Leadless Technology **VIS®**

The ETL-79 Series is one of the smallest amplified transducers currently available. It incorporates the latest pressure sensing technology – Kulite's dielectrically isolated, silicon on silicon, patented leadless sensing element, which enables this device to be used in harsh environments. The ETL-79 microprocessor corrected transducer offers high accuracy with a total error band of $\pm 0.10\%$ FSO Typical, inclusive of all errors over a wide temperature range of 50°F to +250°F.

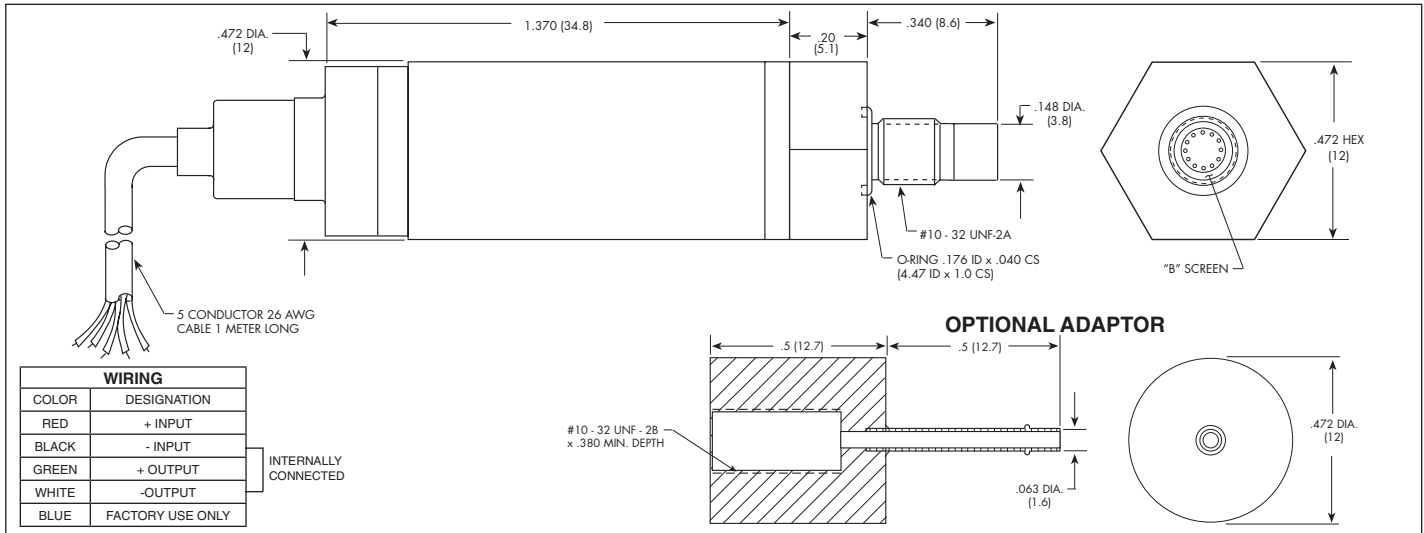

INPUT Pressure Range	.35 5	1.7 25	3.5 50	7 100	17 250	35 BAR 500 PSI
Operational Mode	Absolute, Sealed Gage					
Over Pressure	2 Times Rated Pressure to a Maximum of 5000 PSI (350 BAR)					
Burst Pressure	3 Times Rated Pressure to a Maximum of 5000 PSI (350 BAR)					
Pressure Media	Any Media Compatible With SiO ₂ and 15-5 Stainless Steel					
Rated Electrical Excitation	8 - 32 VDC					
Maximum Electrical Current	25 mA (Max.)					
OUTPUT						
Output Impedance	750 Ohms (Max.)					
Full Scale Output (FSO) (Net)	4.0 VDC \pm .025 VDC					
Total Error Band (Excluding End Points)	\pm 0.2% (Max.) (Combined Non-Linearity, Hysteresis, Repeatability and All Thermal Effects Included)					
Bandwidth (-3dB)	DC to 10 KHz					
Residual Unbalance	0.5 VDC \pm .025 VDC					
Resolution	Infinitesimal					
Acceleration Sensitivity % FS/g Perpendicular	1.5x10 ⁻³	5.0x10 ⁻⁴	3.0x10 ⁻⁴	1.5x10 ⁻⁴	1.0x10 ⁻⁴	6.0x10 ⁻⁵
Transverse	2.2x10 ⁻⁴	6.0x10 ⁻⁵	4.0x10 ⁻⁵	2.0x10 ⁻⁵	1.0x10 ⁻⁵	6.0x10 ⁻⁶
Insulation Resistance	100 Megohm Min. @ 50 VDC					
ENVIRONMENTAL						
Operating Temperature Range	-40°F to +265°F (-40°C to +130°C)					
Compensated Temperature Range	50°F to +250°F (10°C to +120°C)					
Linear Vibration	50g Peak, Sine 10 to 2000 Hz					
Altitude	-150 ft. to +70,000 ft. Will Not Damage Sensor					
Humidity	100% Relative Humidity					
Mechanical Shock	100g half Sine Wave 11 msec. Duration					
PHYSICAL						
Electrical Connection	5 Conductor 26 AWG Viton Cable 1 Meter Long					
Weight	10 Grams Excluding Cable					
Pressure Sensing Principle	Fully Active Four Arm Wheatstone Bridge Dielectrically Isolated Silicon on Silicon Patented Leadless Technology					
Mounting Torque	15 Inch-Pounds (Max.)					

Note: Custom pressure ranges, accuracies and mechanical configurations available. Dimensions are in inches. Dimensions in parenthesis are in millimeters. Continuous development and refinement of our products may result in specification changes without notice - all dimensions nominal. (F)